



Warewashing Systems

List Price Guide

Effective January 1, 2016



Avenger®

*Avenger®
Series
Undercounters*



Delta®

*Delta®
Series
Glasswashers*



TempStar®

*TempStar®
Series
High Temp*



Conserver®

*Conserver®
Series
Low Temp*



CREW®

*CREW®
Series
Conveyors*



LoH₂O®

*JFT® Series
Flight
Machines*

Clean the First Time®

Jackson WWS, Inc.

FLIGHTS / CONVEYORS / DOOR-TYPES / GLASSWASHERS / UNDERCOUNTERS

Phone: 1-888-800-5672 / Web: www.jacksonwws.com / Email: info@jacksonwws.com



AVENGER® HT-E

High-Temperature Sanitizing Dishmachine with Built-In Booster Heater

Sensor Touch start with auto-fill, built-in booster heater, cleans up to 26 racks per hour, 0.73 gallons per rack, Sani-Sure™ final rinse system, stainless steel wash pump assembly, pumped drain, digital and electromechanical components, delimer switch, built-in chemical pumps, priming switches, auto stop, one peg and one combination rack included. 208/60/1 or 230/60/1



CLICK or SCAN to download the Avenger HT-E spec sheet

\$7,000 



AVENGER® LT

Chemical Sanitizing Dishmachine

Cleans up to 24 racks per hour, 1.2 gallons per rack, stainless steel self-draining wash pump assembly, pumped drain, universal controller, delimer switch, low product indicator light, chemical pumps and priming switches, auto stop, auto fill, one peg and one combination rack included. 115/60/1



CLICK or SCAN to download the Avenger LT spec sheet

\$6,500 

Avenger® Series Options & Accessories



Model HT -E only
Drain Quench System
06401-002-59-99
\$350



Water Hammer Arrestor
05700-002-64-67
\$240



Scale Prevention Sys (SPS)
04730-003-28-03
\$575



Cartridge for SPS
04730-003-28-04
\$500



6" Machine Stand
M24STND-6
\$406



18" Machine Stand
M24STND-18
\$540



Avenger HT-E
Back Panel
05700-004-23-52
\$200



Avenger LT
Back Panel
05700-003-33-55
\$200



36-Compartment Rack
4-1/8" Tall
07320-002-86-70
\$91



36-Compartment Rack
5-5/8" Tall
07320-002-86-71
\$105

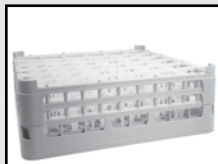

36-Compartment Rack
7" Tall
07320-002-86-72
\$112



6-Compartment Basket
Silverware
07320-100-08-01
\$75



Casters (set of 4)
05700-002-37-82
\$98

1/2" Pressure Regulator
04820-100-04-07
\$180



Tie Down
06401-002-40-56
\$200



20x20 Combination Rack
07320-100-36-00
\$91



20x20 Peg Rack
07320-100-35-00
\$91

480V Electrical
(Model HT-E only)
\$595

Security Package
\$1,500



DELTA® 5-E

Chemical Sanitizing Door-Type Glasswasher/ Dishwasher

Rated by NSF as both a glasswasher and a dishwasher, 90-second cycle, accommodates glasses and wares up to 11" high, electromechanical controls, built-in sustainer heater, easy access controls, chemical pumps, universal controller, delimer switch, built-in stainless steel scrap accumulator, side enclosure panels and two half-racks included. 115/60/1

\$6,800



CLICK or SCAN to download the Delta 5-E spec sheet



DELTA® ROTARY SERIES

Rotary-Type Glasswasher

Cleans 1,200 glasses per hour, uses 10 gallons water per hour, single switch operation, built-in chemical pumps and priming switches, hot or cold fresh water final rinse, convenient chemical storage and easy access scrap screens. Clockwise rotation.

Delta® 1200 208-230/60/1

\$8,000

Delta® 115 115/60/1

\$6,800



CLICK or SCAN to download the Delta 1200 spec sheet



CLICK or SCAN to download the Delta 115 spec sheet

Delta® Series Options & Accessories



Water Hammer Arrestor
05700-002-64-67
\$240



Scale Prevention Sys (SPS)
04730-003-28-03
\$575



Cartridge for SPS
04730-003-28-04
\$500



Scrap Tray
06401-031-66-21
\$300



Delta 5-E Only
Half Rack
07320-002-76-80
\$43



Delta 5-E Only
20x20 Combination Rack
07320-100-36-00
\$91



Delta 5-E Only
20x20 Peg Rack
07320-100-35-00
\$91



Delta 5-E Only
4-1/8" Tall
36-Compartment Rack
07320-002-86-70
\$91



Delta 5-E Only
5-5/8" Tall
36-Compartment Rack
07320-002-86-71
\$105



Delta 5-E Only
7" Tall
36-Compartment Rack
07320-002-86-72
\$112

NEW



TEMPSTAR®
WITH VENTLESS & ENERGY RECOVERY

Door-Type Dishmachine with Electric Tank Heat & Built-In Booster Heater

No vent hood required. Accommodates a wide range of water inlet temperatures and operates with only a cold water connection. Single rack, electric tank heat with built-in 70° F booster heater, Sani-Sure™ final rinse system, up to 39 racks per hour, 0.89 gallons per rack, self-draining stainless steel wash pump, four selectable wash cycles, delimer switch, auto start/stop, door interlock, pressure regulator, exhaust vent fan control, field convertible for straight-through to corner and vice versa, field conversion capability, front stainless steel dress panel. 208 or 230v, single or three phase, 60Hz.

\$16,500

Machine with Steam Tank Heat\$15,400



CLICK or SCAN to download the TempStar Ventless spec sheet

NEW

27"
HIGH CHAMBER



TEMPSTAR® HH
WITH VENTLESS & ENERGY RECOVERY

High Hood Door-Type with Electric Tank Heat & Built-in Booster Heater

No vent hood required. Accommodates a wide range of water inlet temperatures and operates with only a cold water connection. High hood single rack, electric tank heat with built-in 70° F booster heater, Sani-Sure™ final rinse system, 27" clearance for wares, up to 37 racks per hour, 1.36 gallons per rack, dual counter-rotating lower wash arms, self-draining stainless steel wash pump, four selectable wash cycles, delimer switch, auto start/stop, door interlock, pressure regulator, exhaust vent fan control, field convertible for straight-through to corner and vice versa, front stainless steel dress panel. 208 or 230v, single or three phase, 60Hz.

\$19,000

Machine with Steam Tank Heat\$17,900



CLICK or SCAN to download the TempStar HH Ventless spec sheet



TEMPSTAR®

Door-Type Dishmachine with Electric Tank Heat & Built-In Booster Heater

Single rack, electric tank heat with built-in 70° F booster heater, Sani-Sure™ final rinse system, up to 58 racks per hour, 0.89 gallons per rack, self-draining stainless steel wash pump, four selectable wash cycles, delimer switch, auto start/stop, exhaust vent fan control, field convertible for straight-through to corner and vice versa, field conversion capability, front stainless steel dress panel. 208 or 230v, single or three phase, 60Hz.

\$12,500 

Machine with Steam Tank Heat*\$11,400

Machine without Booster Heater*\$10,600

**Requires 180° F incoming water*



CLICK or SCAN to download the TempStar spec sheet

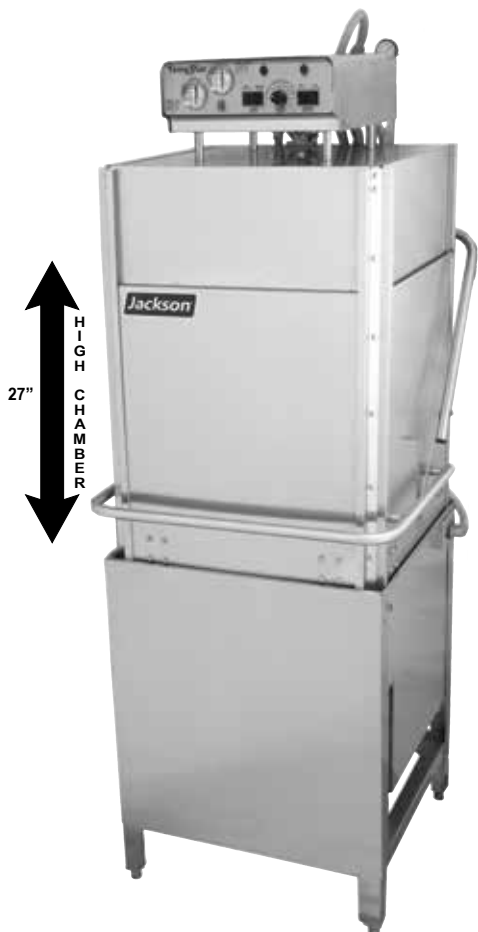

TEMPSTAR® HH

High Hood Door-Type with Electric Tank Heat & Built-in Booster Heater

High hood single rack, electric tank heat with built-in 70° F booster heater, Sani-Sure™ final rinse system, 27" clearance for wares, up to 53 racks per hour, 1.36 gallons per rack, dual counter-rotating lower wash arms, self-draining stainless steel wash pump, four selectable wash cycles, delimer switch, auto start/stop, exhaust vent fan control, field convertible for straight-through to corner and vice versa, front stainless steel dress panel. 208 or 230v, single or three phase, 60Hz.

\$15,000

Machine with Steam Tank Heat*\$13,900

Machine without Booster Heater*\$13,100

**Requires 180° F incoming water*



CLICK or SCAN to download the TempStar HH spec sheet

TEMPSTAR® GPX

Door-Type with Gas Tank Heat & External Booster Heater

Single rack, gas tank heat with integrated external gas booster heater, up to 57 racks per hour, 1.0 gallon per rack, self-draining stainless steel wash pump, four selectable wash cycles, delimer switch, auto start/stop, exhaust vent fan control, field convertible for straight-through to corner and vice versa, front stainless steel dress panel. 115/60/1, 208/60/1 or 230/60/1.

\$21,900



CLICK or SCAN to download the TempStar GPX spec sheet

TEMPSTAR® HH GPX

High Hood Door-Type with Gas Tank Heat & External Booster Heater

High hood single rack, gas tank heat with integrated external gas booster heater, 27" clearance for wares, up to 53 racks per hour, 1.36 gallons per rack, dual counter-rotating lower wash arms, self-draining stainless steel wash pump, four selectable wash cycles, delimer switch, auto start/stop, exhaust vent fan control, field convertible for straight-through to corner and vice versa, front stainless steel dress panel. 115/60/1; 208 or 230v, single or three phase, 60Hz.

\$26,000



CLICK or SCAN to download the TempStar HH GPX spec sheet

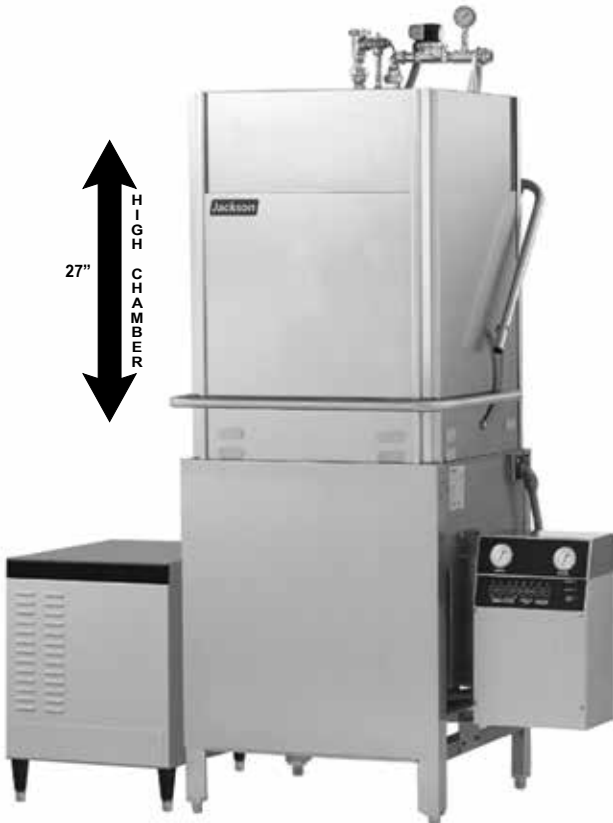
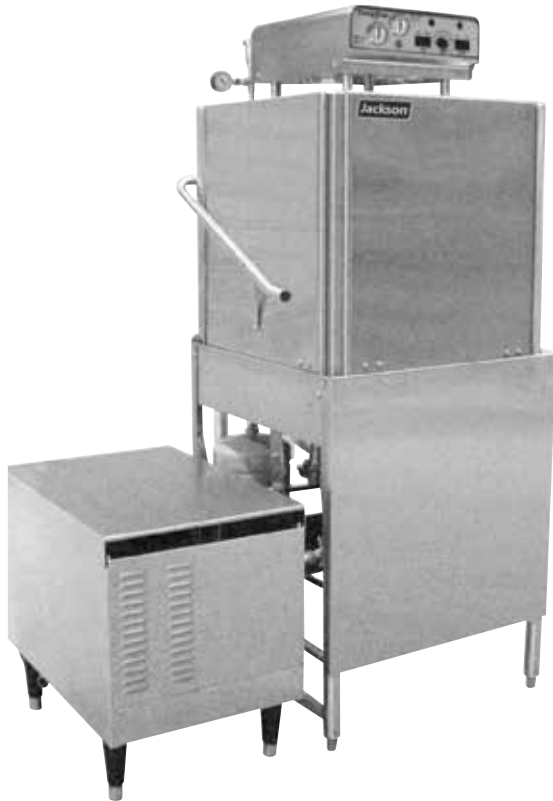

TempStar® Series Options & Accessories

TempStar Models	TempStar HH Models	TempStar HH Models	TempStar Models	TempStar HH Models															
Drain Quench System 06401-004-07-86 \$700	Water Hammer Arrestor 05700-002-64-67 \$240	Water Hammer Arrestor 05700-002-61-29 \$240	False Panel 05700-002-75-59 \$200	False Panel 05700-002-52-89 \$250	Steam Booster Heater 05700-002-98-86 \$5,038														
TempStar Models	TempStar HH Models																		
Flanged Feet (set of 4) 05340-002-34-86 \$200	Flanged Feet (set of 4) 05340-002-01-15 \$200	Scaltrol Water Treatment 04730-003-05-76 \$350	Cartridge for Scaltrol RSC-100 \$275	20x20 Combination Rack 07320-100-36-00 \$91	20x20 Peg Rack 07320-100-35-00 \$91														
				<table border="0"> <tr> <td>480V Electrical</td> <td>\$596</td> </tr> <tr> <td>50 Hz Cycle</td> <td>\$1,009</td> </tr> <tr> <td>208-230/60/1</td> <td>N/C</td> </tr> <tr> <td>Safety Door Interlock</td> <td>\$1,009</td> </tr> <tr> <td>1/2" Pressure Regulator (TempStar) 04820-100-04-07</td> <td>\$180</td> </tr> <tr> <td>3/4" Pressure Regulator (TempStar HH) 06685-011-58-22</td> <td>\$200</td> </tr> <tr> <td>Security Package</td> <td>\$2,500</td> </tr> </table>		480V Electrical	\$596	50 Hz Cycle	\$1,009	208-230/60/1	N/C	Safety Door Interlock	\$1,009	1/2" Pressure Regulator (TempStar) 04820-100-04-07	\$180	3/4" Pressure Regulator (TempStar HH) 06685-011-58-22	\$200	Security Package	\$2,500
480V Electrical	\$596																		
50 Hz Cycle	\$1,009																		
208-230/60/1	N/C																		
Safety Door Interlock	\$1,009																		
1/2" Pressure Regulator (TempStar) 04820-100-04-07	\$180																		
3/4" Pressure Regulator (TempStar HH) 06685-011-58-22	\$200																		
Security Package	\$2,500																		
TempStar HH Models	4-1/8" Tall	5-5/8" Tall	7" Tall																
Sheet Pan Rack 5010-BP \$300	36-Compartment Rack 07320-002-86-70 \$91	36-Compartment Rack 07320-002-86-71 \$105	36-Compartment Rack 07320-002-86-72 \$112																



MODEL 10 A

Round Dishwasher

High-temperature sanitizing dishmachine, up to 45 racks per hour, counter-rotating wash arms, manual control back-up system, 17 1/4" inside chamber clearance, wash and rinse temperature gauges, external vacuum breaker, requires 180° F incoming water supply (optional booster heater available). 208 or 230, single or three phase, 60Hz.

\$12,500

Model 10 AB \$14,750

Model 10 A plus 6.5kW Built-in Booster Heater

Model 10 APRB \$16,500

Model 10 AB plus 1/2 hp Final Rinse Pump



CLICK or SCAN to download the Model 10 spec sheet

Model 10 Options & Accessories

Round Peg Rack 07320-100-09-01 \$195	Round Combination Rack 07320-100-13-01 \$175	Round 12-Compartment 07320-100-17-01 \$195	Silverware 6-Compartment Basket 07320-100-08-01 \$75



CONSERVER® XL-E

Single Rack Door-Type Dishmachine

Cleans up to 39 racks per hour, 1.02 gallons per rack, stainless steel self-draining wash pump assembly, electromechanical controls, delimer switch, low product indicator light, chemical pumps and priming switches, interchangeable upper and lower stainless steel wash/rinse arms, field convertible from straight-through to corner and vice versa, auto start/stop, built-in stainless steel waste accumulator. 115/60/1

\$5,300 



CLICK or SCAN to download the
Conserver XL-E spec sheet

NEW

27"
HIGH
CHAMBER



CONSERVER® XL HH

High Hood Single Rack Door-Type Dishmachine

Cleans up to 39 racks per hour, 1.61 gallons per rack, stainless steel self-draining wash pump assembly, electromechanical controls, delimer switch, low product indicator light, chemical pumps and priming switches, interchangeable upper and lower stainless steel wash/rinse arms, field convertible from straight-through to corner and vice versa, auto start/stop, built-in stainless steel waste accumulator. 115/60/1

\$7,200 



CLICK or SCAN to download the
Conserver XL HH spec sheet

CONSERVER® XL2



Dual Rack Door-Type Dishmachine

Dual rack straight, up to 74 racks per hour, 1.17 gallons per rack, self-draining stainless steel wash pump assemblies, mechanical timer, delimer switch, low product indicator light, chemical pumps and priming switches, interchangeable upper and lower stainless steel wash/rinse arms auto start/stop, built-in stainless steel scrap accumulator. 115/60/1

\$7,800



CLICK or SCAN to download the Conserver XL2 spec sheet

Conserver XL2C\$8,300

Same specifications as the Conserver XL2, except for corner installations. Specify right front (R) or left front (L) door opening.

Conserver® Series Options & Accessories



Water Hammer Arrestor
05700-002-61-29 - XL2 & XLC
05700-002-64-67 - XL-E & XL HH
\$240



Conserver XL-E False Panel
05700-002-51-66
\$200



Conserver XL HH False Panel
05700-002-52-89
\$250



Flanged Feet (set of 4)
05340-002-34-86
\$200



Scaltrol Water Treatment
04730-003-05-76
\$350



Cartridge for Scaltrol RSC-100
\$275



Conserver XL HH Sheet Pan Rack
5010-BP
\$300



20x20 Combination Rack
07320-100-36-00
\$91



20x20 Peg Rack
07320-100-35-00
\$91



4-1/8" Tall 36-Compartment Rack
07320-002-86-70
\$91



5-5/8" Tall 36-Compartment Rack
07320-002-86-71
\$105



7" Tall 36-Compartment Rack
07320-002-86-72
\$112

230/60/1
\$527

Low Product Audible Alarm
06401-003-93-47
\$200

50Hz Cycle
\$1,009

CREW® 44

44" Single Tank Conveyor

Single tank conveyor dishmachine, high temp or chemical sanitizing, 223 racks/hour and 0.35 gallons/rack, WISR® Cleaning System, Rainbow Rinse™, adjustable vent cowl collars, 24V DC control circuit, large front access for ease of maintenance, PLC controls, digital temperature readout, EnergyGuard™ system, 19-3/4" standard height clearance, automatic fill, manual/automatic switch, whisper-quiet stainless steel pump assembly, exhaust vent fan control. 208 or 230v, single or three phase, 60Hz.



Shown with optional Door Accent Panels

\$19,500 Electric Tank Heat
\$21,000 Steam Tank Heat



CLICK or SCAN to download the CREW 44 spec sheet



Machine	Racks/Hour	Gallons/Rack	Gallons/Hour	Booster Heater 40°F/70°F
Brand H 44	202	0.62	125	15kW/30kW
Brand C 44	208	0.54	112	12kW/22kW
Brand S 44	232	0.50	118	15kW/30kW
Brand M 44	239	0.43	103	12kW/24kW
AJX-44	225	0.68	153	18kW/30kW
CREW 44	223	0.35	78	12kW/18kW

CREW® 66

66" Single Tank Conveyor (44"+ 22" Pre-Wash)

Single tank conveyor dishmachine with pre-wash, high temp or chemical sanitizing, 223 racks/hour and 0.35 gallons/rack, WISR® Cleaning System, Rainbow Rinse™, adjustable vent cowl collars, 24V DC control circuit, large front access for ease of maintenance, PLC controls, digital temperature readout, EnergyGuard™ system, 19-3/4" standard height clearance, automatic fill, manual/automatic switch, whisper-quiet stainless steel pump assembly, exhaust vent fan control. 208 or 230v, single or three phase, 60Hz.



\$29,500 Electric Tank Heat
\$31,000 Steam Tank Heat



CLICK or SCAN to download the CREW 66 spec sheet

Shown with optional Door Accent Panels

CREW® Series (only) Options & Accessories

A full listing of conveyor options and accessories is located on page 16



Door Accent Panels
 (set of 2)
 Must specify at time of order
\$500



Onboard Booster Heater
 70° F rise/18kW
\$2,500

Single Point Connection

Available on CREW Conveyors with onboard boosters - no upcharge applies.*

*Available on 3-phase machines only



Onboard Booster Heater
 40° F rise/12kW
\$2,250



Table Limit Switch
 Strike Plate **\$350**
 (shown in picture)
 Whisker Switch **\$350**

18kW Wash Tank Heater
 CREW 44 only
N/C

1/2" Pressure Regulator
 04820-100-04-07
\$180

CREW Blower Dryer
\$10,000

AJX-44 SERIES

Single Tank Conveyor

Single tank conveyor dishmachine, dual rated for both high temperature and chemical sanitizing, 225 racks/hour and 0.68 gallons/rack for high temperature, 209 racks/hour and 0.78 gallons/rack for chemical sanitizing, Adjust-A-Peak™ conveyor speed, EnergyGuard™ system, 25" standard height clearance, automatic fill, manual/automatic switch, whisper-quiet stainless steel pump assembly, exhaust vent fan control. 208 or 230v, single or three phase, 60Hz.



AJX-44

44" Conveyor

\$17,500 Electric Tank Heat

\$19,000 Steam Tank Heat



CLICK or SCAN to download the AJX-44 spec sheet



AJX-66

66" Conveyor (44" + 22" Pre-Wash)

\$27,000 Electric Tank Heat

\$28,500 Steam Tank Heat



CLICK or SCAN to download the AJX-66 spec sheet

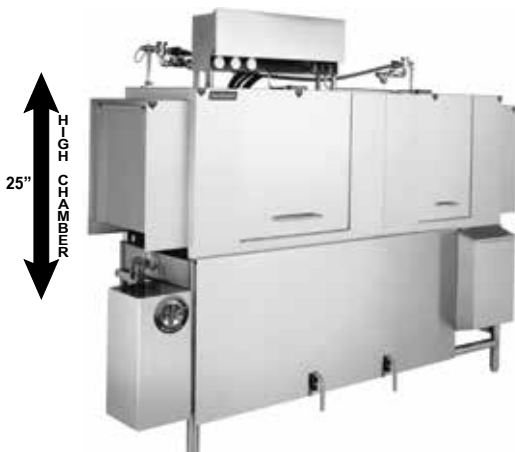

AJX-80

80" Conveyor (44" + 36" Pre-Wash)

\$29,500 Electric Tank Heat

\$31,000 Steam Tank Heat



CLICK or SCAN to download the AJX-80 spec sheet

AJX-54 SERIES

Single Tank Conveyor

Single tank conveyor dishmachine, dual rated for both high temperature and chemical sanitizing, 225 racks/hour and 0.68 gallons/rack for high temperature, 209 racks/hour and 0.78 gallons/rack for chemical sanitizing, Adjust-A-Peak™ conveyor speed, EnergyGuard™ system, 25" standard height clearance, automatic fill, manual/automatic switch, whisper-quiet stainless steel pump assembly, exhaust vent fan control. 208 or 230v, single or three phase, 60Hz.

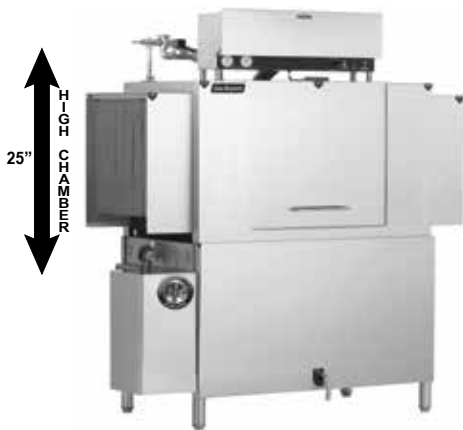

AJX-54

54" Conveyor

\$23,500 Electric Tank Heat

\$25,000 Steam Tank Heat



CLICK or SCAN to download the AJX-54 spec sheet

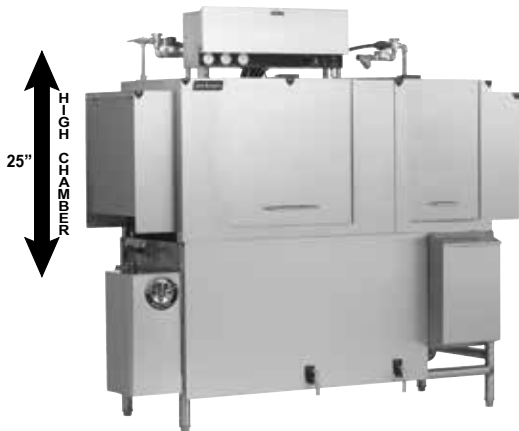

AJX-76

76" Conveyor (54" + 22" Pre-Wash)

\$35,000 Electric Tank Heat

\$36,500 Steam Tank Heat



CLICK or SCAN to download the AJX-76 spec sheet

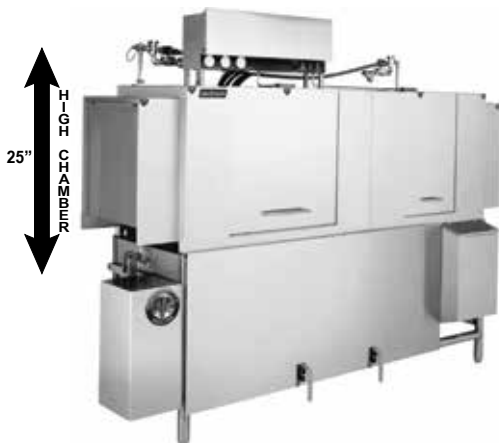

AJX-90

90" Conveyor (54" + 36" Pre-Wash)

\$37,500 Electric Tank Heat

\$39,000 Steam Tank Heat



CLICK or SCAN to download the AJX-90 spec sheet

AJ-44 SERIES

Single Tank Conveyor

Single tank, gas tank heat conveyor dishmachine, 248 racks/hour and 0.94 gallons/rack, Adjust-A-Peak™ conveyor speed, EnergyGuard™ system, 25" standard height clearance, automatic fill, manual/automatic switch, whisper-quiet stainless steel pump assembly, exhaust vent fan control. Includes external booster heater. 208 or 230v, single or three phase, 60Hz.

AJ-44



44" Single Tank Conveyor with Gas Tank Heat

\$34,000



CLICK or SCAN to download the AJ-44 spec sheet

AJ-66



66" Single Tank Conveyor with Gas Tank Heat (44" + 22" Pre-Wash)

\$44,500



CLICK or SCAN to download the AJ-66 spec sheet

AJ-80

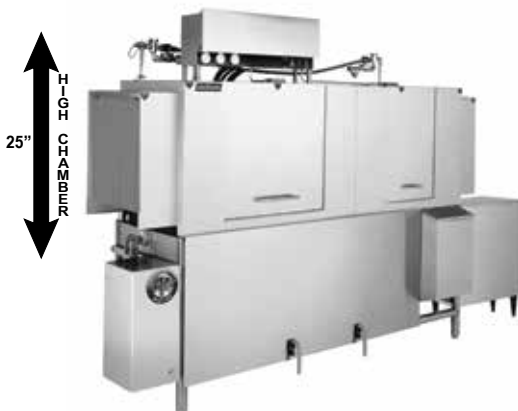

80" Single Tank Conveyor with Gas Tank Heat (44" + 36" Pre-Wash)

\$47,000



CLICK or SCAN to download the AJ-80 spec sheet

AJ-64 SERIES

Dual Tank Conveyor

Dual tank conveyor dishmachine, 287 racks/hour and 0.77 gallons/rack, Adjust-A-Peak™ conveyor speed, EnergyGuard™ system, 25" standard height clearance, automatic fill, manual/automatic switch, whisper-quiet submerged stainless steel pump assembly, exhaust vent fan control. 208 or 230v, single or three phase, 60Hz.

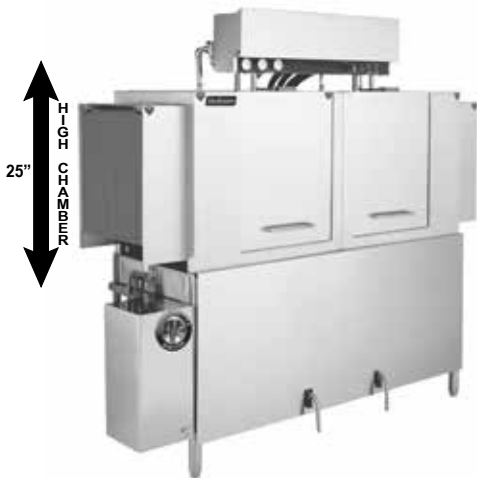

AJ-64

64" Dual Tank Conveyor

- \$36,000** Electric Tank Heat
- \$37,500** Steam Tank Heat
- \$50,000** Gas Tank Heat†



CLICK or SCAN to download the AJ-64 spec sheet

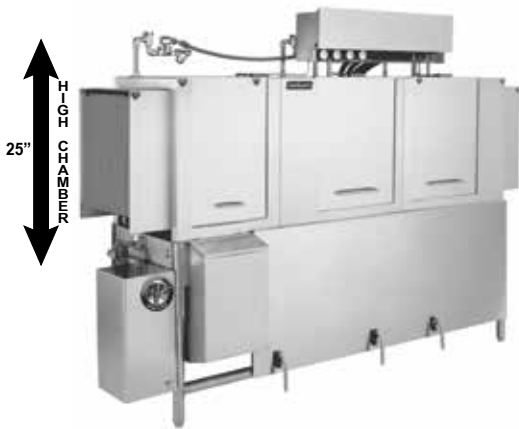

AJ-86

86" Dual Tank Conveyor (64" + 22" Pre-Wash)

- \$46,000** Electric Tank Heat
- \$48,000** Steam Tank Heat
- \$61,000** Gas Tank Heat†



CLICK or SCAN to download the AJ-86 spec sheet



AJ-100

100" Dual Tank Conveyor (64" + 36" Pre-Wash)

- \$48,500** Electric Tank Heat
- \$50,500** Steam Tank Heat
- \$63,500** Gas Tank Heat†



CLICK or SCAN to download the AJ-100 spec sheet

†Includes External Gas Booster Heater

Conveyor Options & Accessories



CREW Models
Door Accent Panels
 (set of 2)
 Must specify at time of order
\$500



CREW Models
Onboard Booster Heater
 70° F rise/18kW **\$2,500**
 40° F rise/12kW **\$2,250**



Table Limit Switch
Strike Plate \$350
 (shown in picture)
Whisker Switch \$350



Flanged Feet
 (set of 4)
 05340-002-15-47
\$300

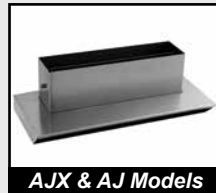

AJX & AJ Models
Vent Cowl Collar
 (set of 2)
 05700-002-04-08
\$400



CREW & AJX Models
Water Hammer Arrestor
 05700-002-64-67
\$240



AJ Models
Water Hammer Arrestor
 05700-002-61-29
\$240



Drain Quench System
 06401-002-44-07
\$900



Cold Water Thermostat
 05930-121-75-66
\$385



Steam Booster Heater
 05700-002-98-86
\$5,038



Scaltrol Water Treatment
 04730-003-05-76
\$350



Cartridge for Scaltrol RSC-100
\$275



20x20 Combination Rack
 07320-100-36-00
\$91



20x20 Peg Rack
 07320-100-35-00
\$91



Sheet Pan Rack
 5010-LS
\$300



4-1/8" Tall
36-Compartment Rack
 07320-002-86-70
\$91



5-5/8" Tall
36-Compartment Rack
 07320-002-86-71
\$105



7" Tall
36-Compartment Rack
 07320-002-86-72
\$112

480V Electrical	All models	\$918
50Hz Cycle	AJX & AJ models	\$918
Dual Point Connection	AJX & AJ models	\$600
Single Point Connection	CREW with onboard booster, 3-phase only	N/C
1/2" Pressure Regulator	04820-100-04-07 (AJX and CREW models)	\$180
3/4" Pressure Regulator	06685-011-58-22 (AJ models)	\$200
Wash Tank Heater	18kW (CREW 44 model)	N/C
Side Loader	23" Unhooded	\$4,890
Side Loader	23" Hooded (25" models)	\$7,015
Side Loader	30" Unhooded	\$6,969
Side Loader	30" Hooded (25" models)	\$7,931
Blower Dryer	CREW models	\$10,000
Blower Dryer	AJX & AJ models	\$10,000
Security Package	All models	\$4,500

Electric Booster Heaters

C-4 Hatco® 4kW	\$1,935	C-18 Hatco® 18kW	\$2,235
C-6 Hatco® 6kW	\$1,995	C-24 Hatco® 24kW	\$2,978
C-7 Hatco® 7kW	\$2,020	C-27 Hatco® 27kW	\$3,015
C-9 Hatco® 9kW	\$2,050	C-30 Hatco® 30kW	\$3,051
C-12 Hatco® 12kW	\$2,158	C-36 Hatco® 36kW	\$3,196
C-15 Hatco® 15kW	\$2,200	C-45 Hatco® 45kW	\$3,612
C-17 Hatco® 17.2kW	\$2,215	C-54 Hatco® 54kW	\$3,725

Recommended Booster Heater Sizing Chart

TEMPERATURE	CREW 44/66	AJX-44/54	AJ-64	AJX-66/76	AJX-80/90	AJ-86	AJ-100
40°F RISE	C-12	C-17	C-36	C-17	C-17	C-36	C-36
70°F RISE	C-17/C-18*	C-30	C-45	C-30	C-30	C-45	C-45

*Booster size determined by voltage and phase. Contact Customer Service for further assistance.

JFT SERIES FLIGHT MACHINES



JFT LoH₂O[®] Rackless Conveyor



Rainbow Rinse™ produces superior results while significantly reducing water consumption



Specially designed wash arms with non-clogging, convex jets provide equalized water pressure and uniform cleanability



Reliable electromechanical controls and digital temperature readouts for each wash tank and final rinse

Rackless conveyor, up to 11,094 dishes per hour, 58 gallons of water per hour, Rainbow Rinse™ final rinse arm, non-clogging wash and rinse arm nozzles, sequential digital temperature readout of each tank, door safety switches, belt tension adjustment, large removable scrap screens.

Also available in our 139.2 gallon/14,964 dishes per hour model - JFT

Assembly of all flight sections - including internal wiring, piping, thermometers and leveling of the machine - is performed by Jackson factory-authorized personnel. The Jackson factory authorized personnel will also conduct a performance test and operator training at time of assembly. Final utility connections for plumbing and electrical shall be provided by others and should be conducted by an authorized and licensed tradesman in accordance with local, state and national building codes and guidelines. All Jackson Flight-Type machines come with a one-year Parts & Labor Warranty and a two-year Preventative Maintenance Program (PMP) through the local Jackson Authorized Service Agency (ASA).



CLICK or SCAN to download the JFT LoH₂O spec sheet

Call Factory for Quote

WATER TREATMENT



Scale Prevention Sys (SPS)
04730-003-28-03
\$575



Cartridge for SPS
04730-003-28-04
\$500



Scaltrol Water Treatment
04730-003-05-76
\$350



Cartridge for Scaltrol
RSC-100
\$275

DISHTABLES

DTC-S70-24L	Clean Side 24" - Left side installation	\$945	DTS-S70-36L	Soil Side 36" - Left side installation	\$1,846
DTC-S70-24R	Clean Side 24" - Right side installation	\$945	DTS-S70-36R	Soil Side 36" - Right side installation	\$1,846
DTC-S70-36L	Clean Side 36" - Left side installation	\$1,082	DTS-S70-48L	Soil Side 48" - Left side installation	\$1,904
DTC-S70-36R	Clean Side 36" - Right side installation	\$1,082	DTS-S70-48R	Soil Side 48" - Right side installation	\$1,904
DTC-S70-48L	Clean Side 48" - Left side installation	\$1,188	DTS-S70-72L	Soil Side 72" - Left side installation	\$2,260
DTC-S70-48R	Clean Side 48" - Right side installation	\$1,188	DTS-S70-72R	Soil Side 72" - Right side installation	\$2,260
DTC-S70-72L	Clean Side 72" - Left side installation	\$1,378	DTU-U60-48L	Undercounter Table 48" - Left side	\$1,737
DTC-S70-72R	Clean Side 72" - Right side installation	\$1,378	DTU-U60-48R	Undercounter Table 48" - Right side	\$1,737

Please Call Factory for Custom Dishtable Sizes & Specifications

DISHTABLE ACCESSORIES

B-2147M	Pre-Rinse Spray for use with Overshelf	\$558	DT-6R-22-X	Overshelf 42"	\$872
B-2175M	Pre-Rinse Spray for use w/o Overshelf	\$558	DT-6R-23-X	Overshelf 62"	\$962
07320-500-01-04	Scrap Block	\$257	DTA-100-X	Pre-Rinse Basket with Slide Bar	\$483
DTA-SS-42	Undershelf 42"	\$862			

DISH RACKS



20x20 Combination Rack
07320-100-36-00
\$91



20x20 Peg Rack
07320-100-35-00
\$91



36-Compartment Rack
07320-002-86-70
\$91



36-Compartment Rack
07320-002-86-71
\$105

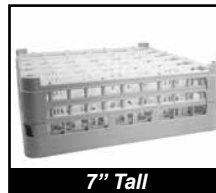

36-Compartment Rack
07320-002-86-72
\$112



Delta 5-E
Half Rack
07320-002-76-80
\$43



Door-Type HH Models
Sheet Pan Rack
5010-BP
\$300



Conveyors
Sheet Pan Rack
5010-LS
\$300



Round Peg Rack
07320-100-09-01
\$195



Round Combination Rack
07320-100-13-01
\$175



Round 12-Compartment
07320-100-17-01
\$195



Silverware
6-Compartment Basket
07320-100-08-01
\$75

GENERAL INFORMATION

TERMS OF SALE: 1% 10 days, net 30 days.

FREIGHT TERMS: F.O.B. Factory prepaid and allowed in the contiguous United States on Jackson manufactured dishmachines, subject to the following surcharges:

Lift-Gate Delivery (<i>all products</i>)	\$75	Inside Delivery (<i>larger than 44"</i>)	\$125
Call Prior to Delivery	\$50	Re-Consignment.....	\$75
Guaranteed Delivery Date	Call Factory	Export or Special Packaging ...	Call Factory
Inside Delivery (<i>44" & smaller</i>)	\$75		

WARRANTY/EXTENDED WARRANTY: All new Jackson manufactured dishmachines are warranted to the original purchaser to be free from defects in material and workmanship, under normal use and operation, for a period of one (1) year from the date of purchase. Extended warranties are available on new Jackson manufactured dishmachines and must be purchased at the time of equipment order. A one (1) year extended warranty is available at a rate of 6% of the machine's list price and a two (2) year extended warranty is available at a rate of 11% of the machine's list price.



FREE START-UP: All new Jackson manufactured dishmachines qualify for a Complimentary Performance & Installation Check by a Jackson Authorized Service Agency (ASA)*. When the machine is installed by a Jackson ASA, this complimentary service is provided at the time of installation.

When the installation is not performed by the local Jackson ASA we will still conduct the Complimentary Performance & Installation Check to verify the installation was done correctly and that the machine is operating properly. Contact Jackson Technical Service to arrange for this service.

**Jackson WWS limits travel time to two (2) hours and mileage to one hundred (100) miles round trip. Jackson WWS will not pay for travel time and mileage that exceed this, or any fees such as those for air or boat travel without prior authorization. For machines located beyond the above stated limitations, please contact Jackson Technical Service for assistance via phone, 1-888-800-5672.*

QUICK-SHIP PROGRAM: All items marked with  are part of Jackson's Quick Ship Program. Standard shipping for these products is 1 to 2 business days. Please contact Jackson Customer Service for lead times on all other products.

RETURNS: All returns must be authorized in writing by Jackson and are subject to a 25% restocking fee and freight charges both ways.

**ALL PRICES ARE IN U.S. DOLLARS.
ALL PRICES, TERMS, ITEMS & SPECIFICATIONS
ARE SUBJECT TO CHANGE WITHOUT NOTICE.**

ABOUT JACKSON

Jackson WWS is a full-line supplier of high-quality commercial dishmachines including flights, conveyors, door-types, glasswashers and undercounters. Founded in 1925, Jackson stands by their “Clean the First Time®” commitment with dishmachines that deliver optimal cleaning performance while reducing labor, chemical and utility costs. With more standard features, lower operating and acquisition costs and our network of factory-certified technicians, Jackson sets the standard for warewashing. For more information about Jackson and its full line of warewashing solutions, please visit www.jacksonwws.com or call 1.888.800.5672.



Jackson WWS List Price Guide
January 1, 2016

Jackson WWS, Inc.

Shipping Address: 6209 North U.S. Highway 25E, Gray, KY 40734
Mailing Address: P.O. Box 1060, Barbourville, KY 40906
Telephone: 888-800-5672 • Fax: 606-523-1799
Email: info@jacksonwws.com
07610-003-59-42 [01/01/16]

www.jacksonwws.com



CLICK or SCAN
to access the
Jackson website