



*This kit is for machines after 23H418053.*

**FALSE PANEL KIT - 06401-005-14-75**



**WARNING:** This kit *should* be installed only by qualified service personnel to reduce the risk of electric shock, serious injury, or fire. A plumbing permit and the services of a licensed plumber and electrician might be required in some areas.

Turn off the power supply and place the dishmachine disconnect (if applicable) in the off position. Lock-out/Tag-out to prevent the power supply from being turned back on inadvertently. Shut-off incoming water.

**CAUTION:** Failure to install these kits within the guidelines might adversely affect safety, performance, component life, and warranty coverage.

**TOOLS REQUIRED**

- Phillips screwdriver
- 7/16 socket/nutdriver

**PARTS INCLUDED**

QTY	DESCRIPTION	PART NUMBER
1	False Panel	05700-005-14-73
2	Instructions	07610-005-16-44

**FALSE PANEL INSTALL**

1. Open door and remove front rack rail from track assembly. Keep hardware. If installing false panel, discard front rack rail and proceed to Step 3. If not installing false panel, proceed to Step 2.

*NXP-HTD shown, left side against wall.*

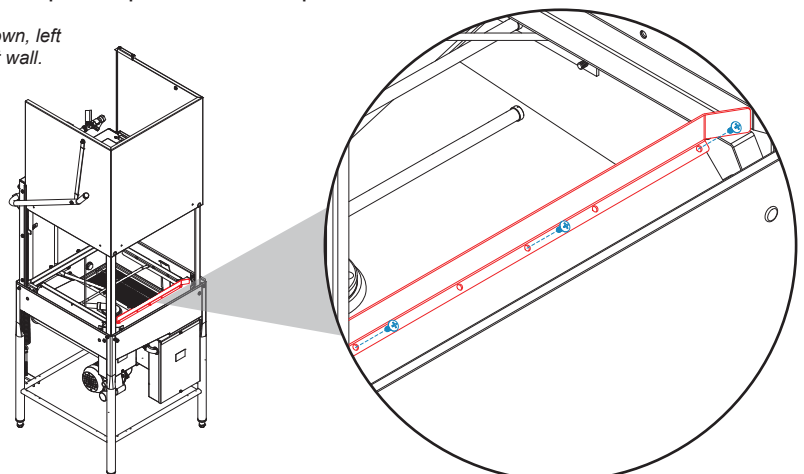

*Machine comes configured for straight-through operation, so track assembly must be converted for a corner operation before installing.*

### FALSE PANEL INSTALL

2. If not using false panel, install rack rail and hardware from Step 1 on wall side of track assembly. Proceed to Corner Install section.

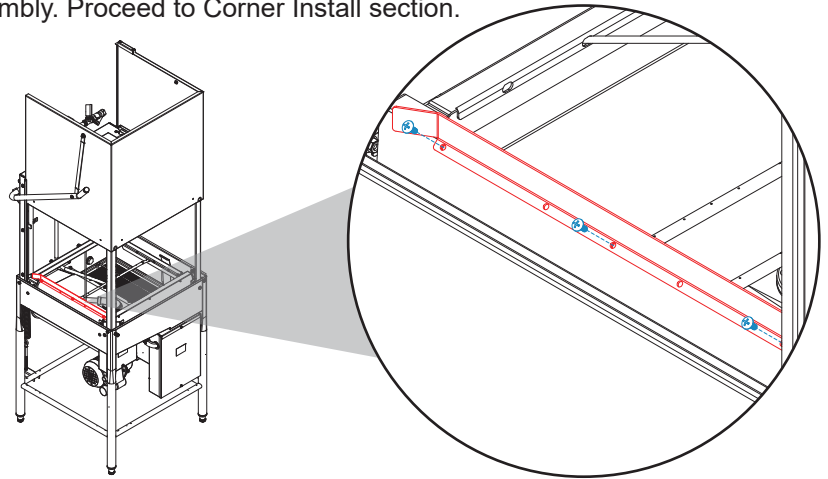

*Left side against wall shown. For right side against wall, install rack rail on right side.*



*False panel MUST be installed before machine is placed in corner.*

*For corners with wall surfaces that are susceptible to water damage, optional false panel reduces amount of water hitting wall whenever door is raised.*

3. If using false panel, remove door stop bracket from wall side with 7/16 socket/nutdriver. Don't remove other door stop bracket.

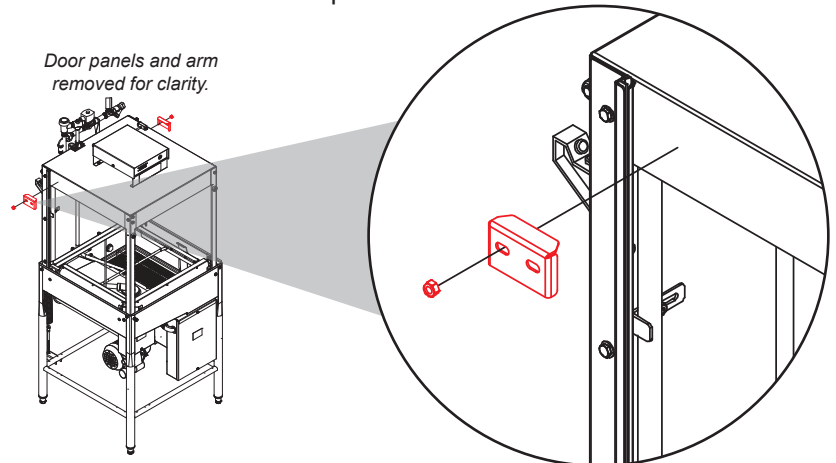

4. Secure top of panel to left side of hood using two slots on panel, then secure bottom to track assembly with hardware from Step 1.

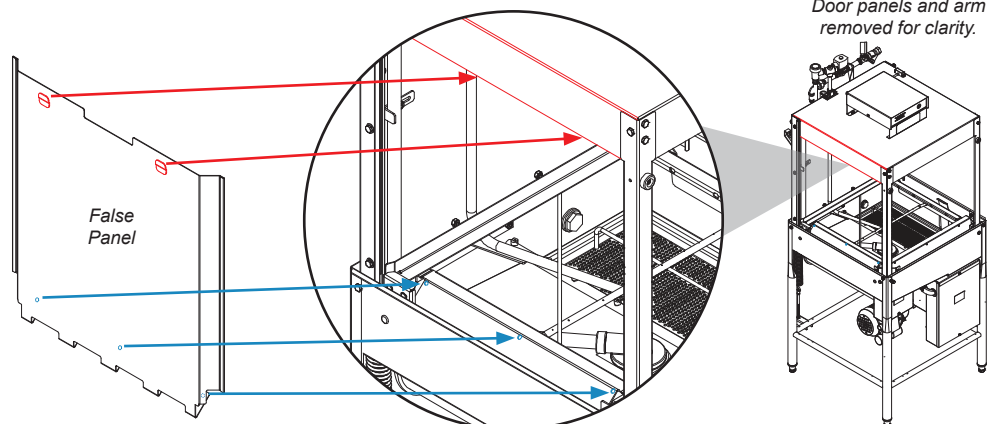

*Left side against wall shown. For right side against wall, remove drain handle and install false panel on right side.*



*MUST remove drain handle for right side against wall installation.*

For right side against wall installation, remove drain handle before installing false panel.

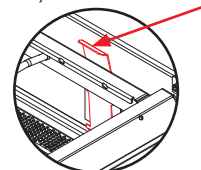

### CORNER INSTALL

1. Locate machine in corner. Left and right installations shown.

*Utilities that are hard to reach should be installed before tables are installed.*

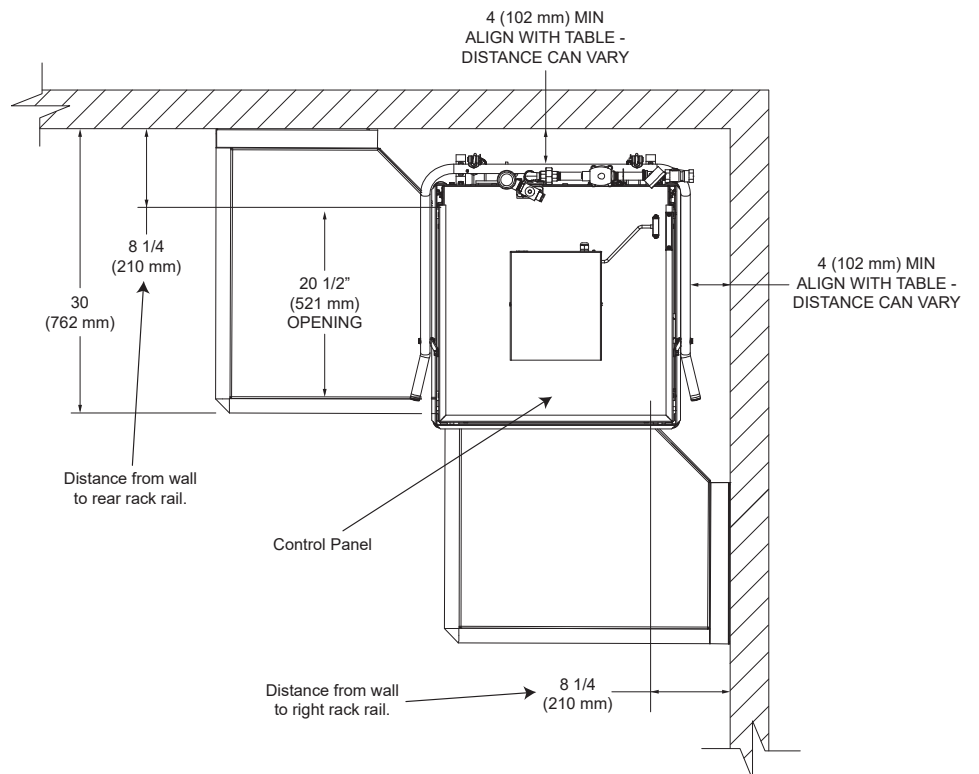
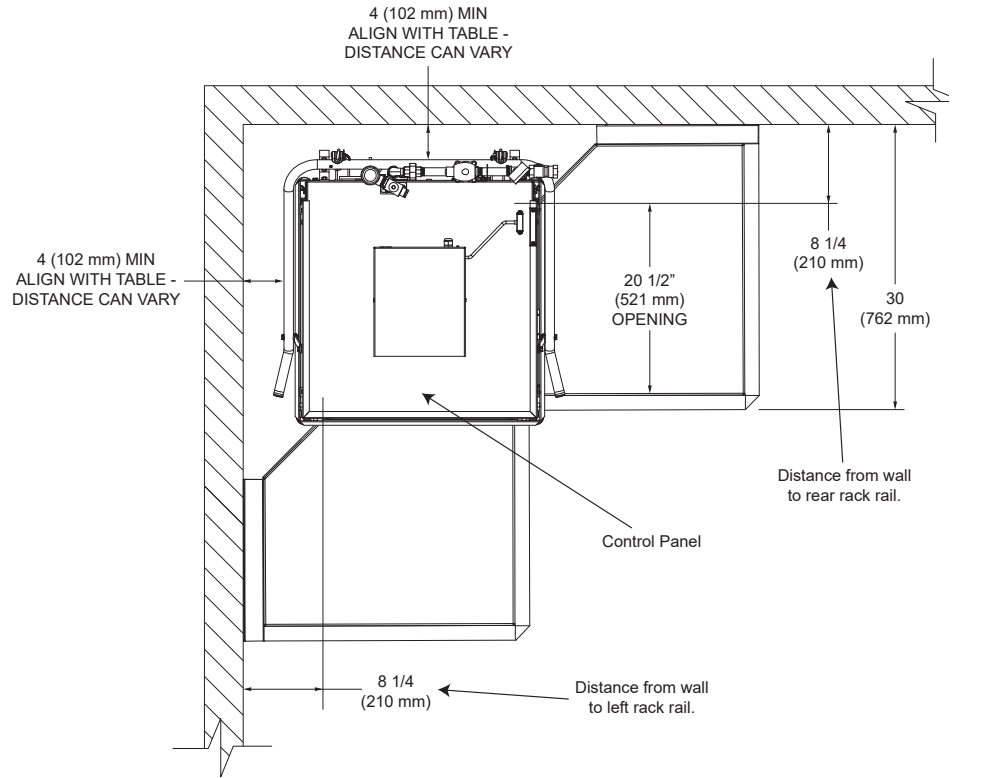

### CORNER INSTALL

*Dish tables are stationary, so machine must be moved until rack rails line-up with proper locations on dish tables. As a result, distances from wall might vary.*

2. Machine must be located so dish tables and rack rails in machine align for proper loading and unloading of dish racks.
3. Install dish tables so edge of each table fits over inner wall of machine tank.

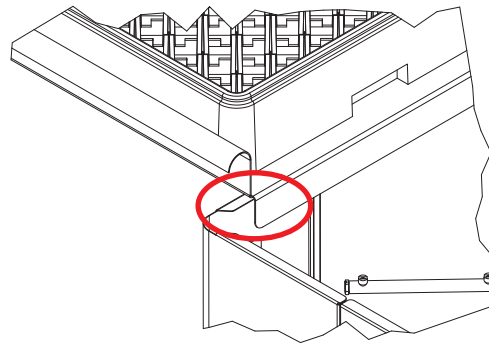

4. Seal each dish table joint with food-grade sealant to prevent leaks.

*Conservex XL-E shown,  
right side against wall.*

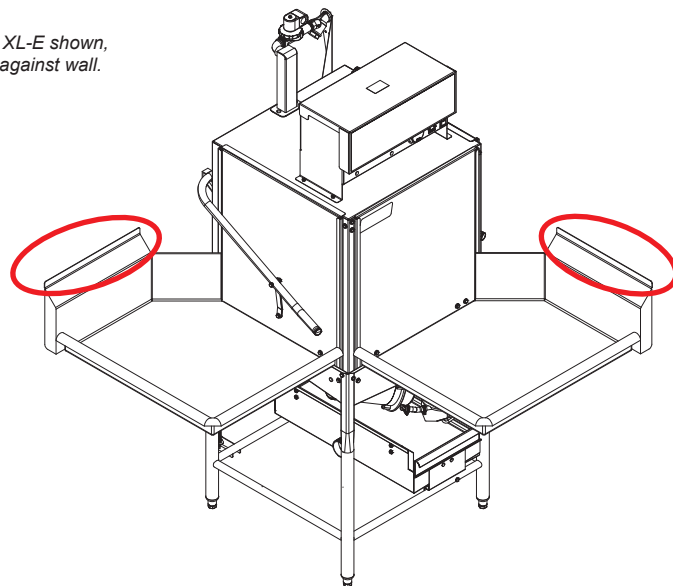

5. Connect remaining utilities according to manufacturer's instructions and all applicable codes and regulations.